

Operating the device correctly
Page: 8

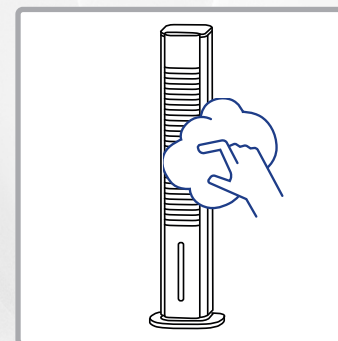

Clean the appliance regularly
Page: 11

Welcome



Please read all the information contained in these instructions for use. Keep the instructions for use in a safe place and pass them on to subsequent users. The device may only be used for its intended purpose in accordance with these instructions. Observe the safety instructions. The device is best operated with an RCD circuit breaker (max. 30mA).



Spare parts and accessories shop
<https://www.trisaelectronics.ch/en/zubehoer/>

Table of Contents

Safety instructions	4	After use	10
Technical data	5	Cleaning	11
Device overview	6	Problems and causes	13
Commissioning	7	User information	14
Application	8		

Safety instructions



Do not cover the appliance while in operation with blankets, cloths or objects – fire hazard!

- Never spray insecticide onto the appliance, as this may damage it.
- Never direct the appliance's airflow directly at children / animals.
- Read all safety instructions, observe the instructions for use, keep them in a safe place and pass them on to subsequent users.
- The appliance is intended for domestic use, not for commercial use. Do not operate the appliance outdoors.
- Not for household waste. The device must be disposed of in accordance with local regulations.
- It is best to operate the device with an RCD (max. 30 mA).
- If the device is misused, operated incorrectly or repaired improperly, no liability can be accepted for any damage that occurs. In this case, the warranty claim is void.
- Never immerse the device in water or other liquids. No liquid must be allowed to enter the interior of the device (risk of short circuit).
- Check the device, power cord and extension cord for damage before each use. Never use damaged devices (including power cords) – have them repaired or replaced by the manufacturer, its service centre or qualified specialists. Never open the device yourself – risk of injury!
- Do not insert fingers or objects into device openings. Do not cover device openings.
- Avoid operating the device in the vicinity of flammable vapours.
- Children must not play with the device. Keep the device and power cord away from children under 8 years of age. Never leave the device unattended during operation. Packaging material (e.g. plastic bags) must be kept out of the reach of children.
- Mains connection: The voltage must correspond to the specifications on the device's type plate.
- Never carry or pull the device by the power cord. Do not kink, pinch or pull the power cord over sharp edges. Risk of short circuit due to cable breakage!
- Never place the device/connection cable on hot surfaces (hotplates) or near open flames. Do not expose the device to intense heat (heating sources, radiators, sunlight). Only extinguish burning devices with a fire blanket.
- Never pull the plug on the power cord or with wet hands. Unplug the device in the event of malfunctions during use, before refilling, before cleaning, before moving or after use. The plug must remain accessible at all times.
- Switch off unused/unattended devices and pull out the mains plug. Do not wrap the mains cable around the device.
- Only operate the device on a flat, stable, dry surface. Never attach it to a wall or ceiling.
- Do not operate/connect the appliance to a timer or remote-controlled switch.
- Children aged 8 years and above and persons with reduced physical, sensory or mental capabilities, or lack of experience and knowledge, may only use the device if they are supervised by a person responsible for their safety or if they have been shown how to use the device safely and understand the dangers involved. Cleaning and maintenance work must not be carried out by children without supervision.
- For safety reasons, do not use accessories that are not recommended/sold by the manufacturer.

Technical data

Item no.: 9381.70

220-240V AC 50	Input voltage	0.07 (m³/min)/W	Efficiency	Approx. 1.5m	Cable length
26 x 28.5 x 106	Dimensions (cm)	6.1 kg	Weight	65 dB(A)	Noise level
5.5 m/s	Max. air velocity	5.3 m³/min	Max. volume flow	1300 RPM	Rotational speed

Power consumption

80 W	When on	<0.5 W	When off	-	OFF/standby mode active after...
-------------	---------	------------------	----------	----------	----------------------------------

Device overview

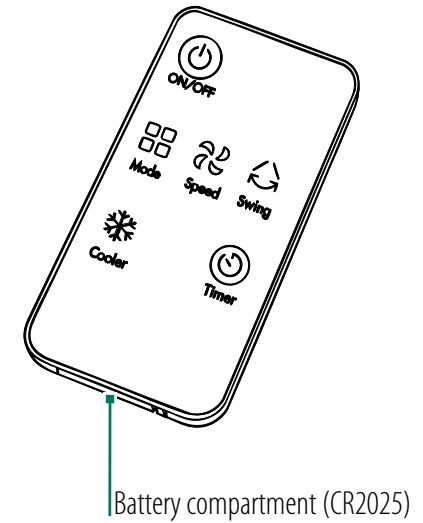
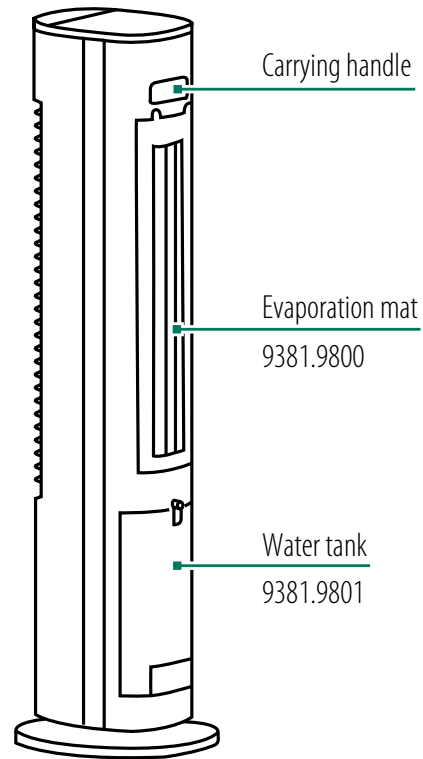
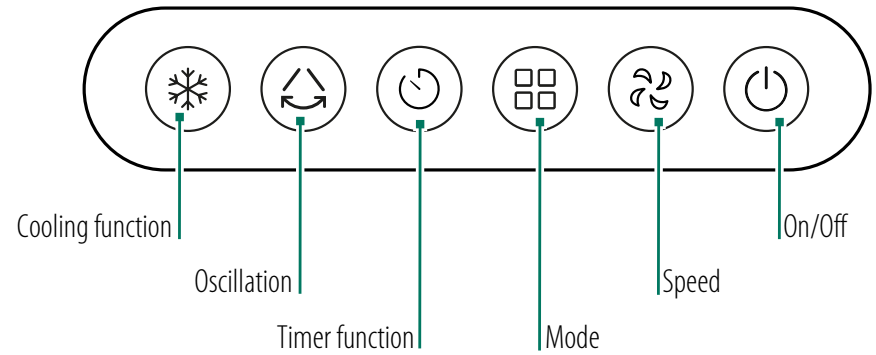
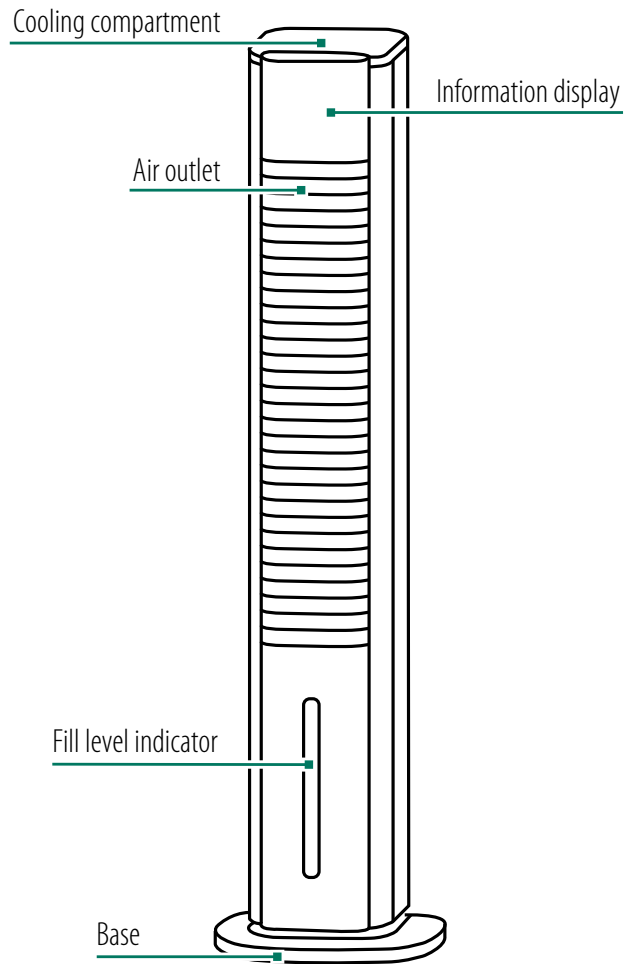

Spare parts and accessories shop
<https://www.trisaelectronics.ch/en/zubehoer/>

Commissioning

1. Fill cooling elements



Fill and freeze the cooling elements.

2. Place the appliance on a stable surface

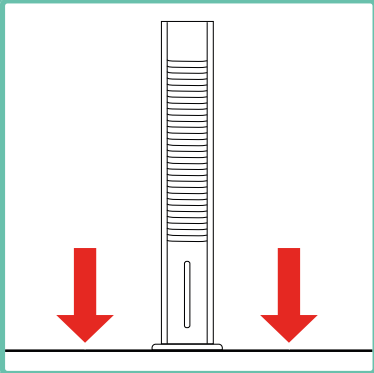

Place the device on a flat, level surface.

3. Fill the water tank

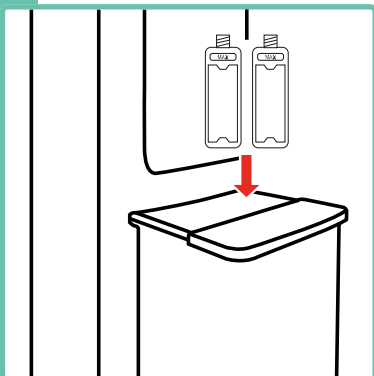

Fill the water tank and insert the cooling elements.

4. Insert the cooling element

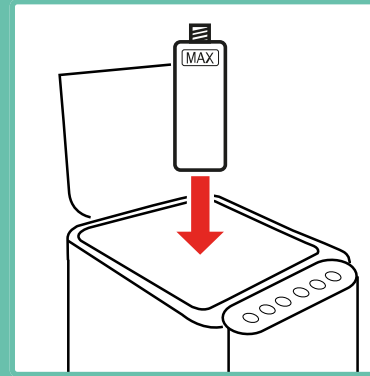

Open the flap and insert the cooling element into the cooling compartment.

5. Fill the water tank

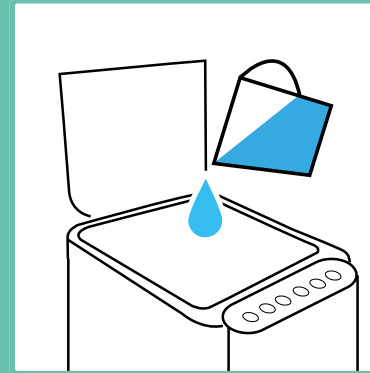

Fill the water tank with water via the cooling compartment.

! Observe the MAX mark.

Application

1. Plug in the device

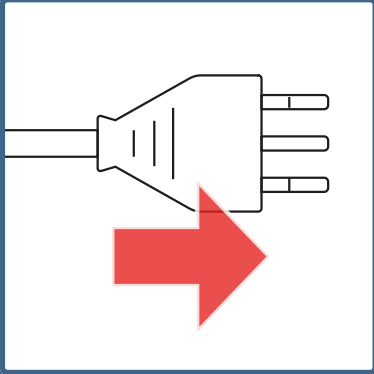

Plug in the device.

2. Turn on the device

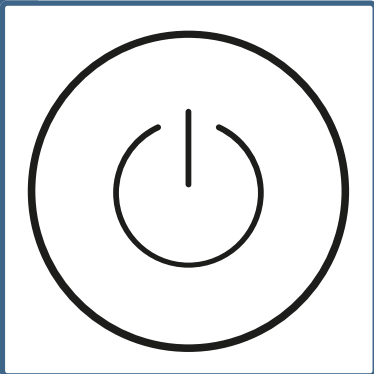

Tap the power button to activate the device.

3. Adjust

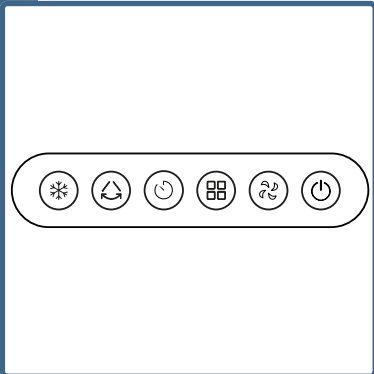

Make the desired settings using the control panel

4. Fan speed

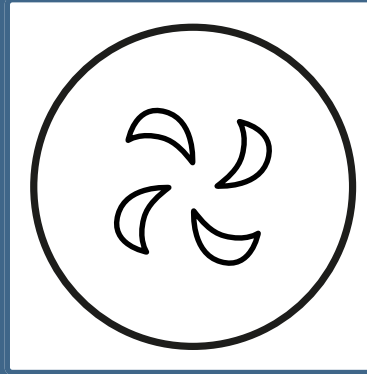

Change the fan speed by tapping the speed button.

Fan speeds:
Low
Medium
High

5. Cooling function

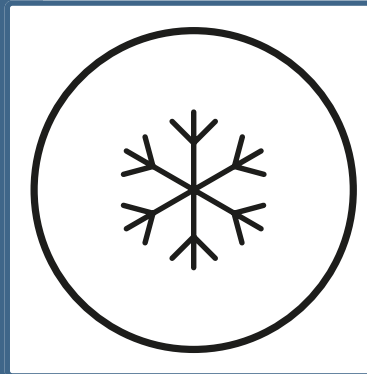

Tap the Cool button to turn the cooling function on or off.

6. Fan mode

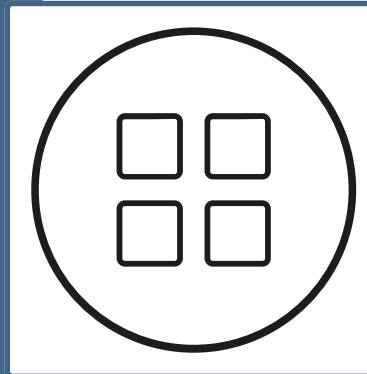

Change the fan mode by tapping the mode button.

7. Oscillation

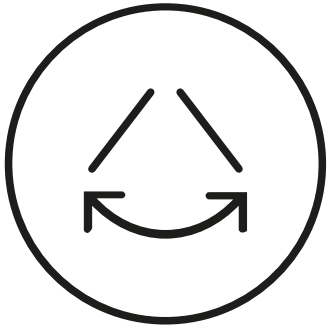

Switch oscillation on and off by tapping the oscillation button.

8. Timer function

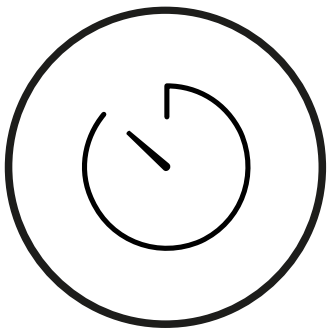

Set the time until the device switches off by tapping the timer button several times. The timer can be set from 1 to 12 hours.

After use

1. Switch off the appliance

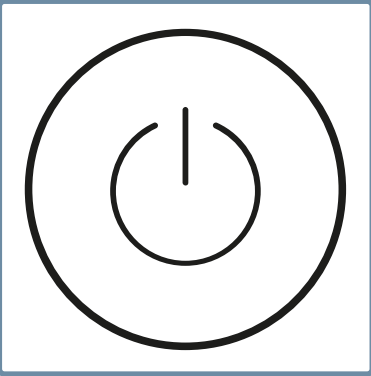

Switch off the device at the main switch.

2. Unplug

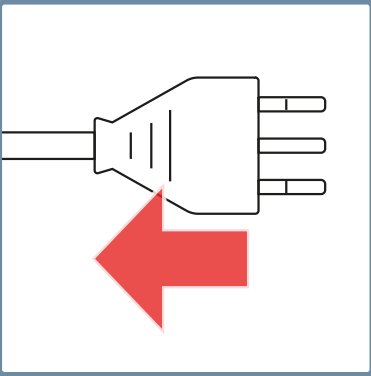

Remove the mains plug.

3. Remove cooling elements

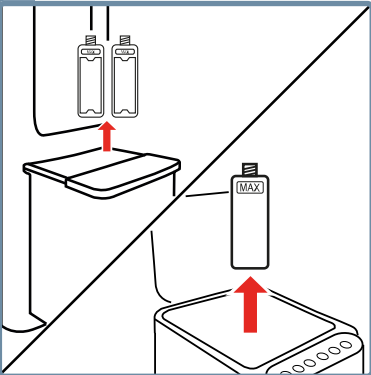

Remove the cooling elements from the water tank and the cooling compartment.

4. Clean the appliance

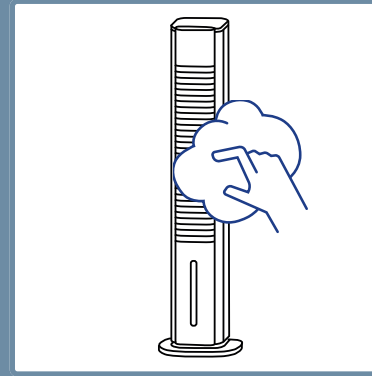

Clean the appliance; see the 'Cleaning' section.

5. Store the appliance

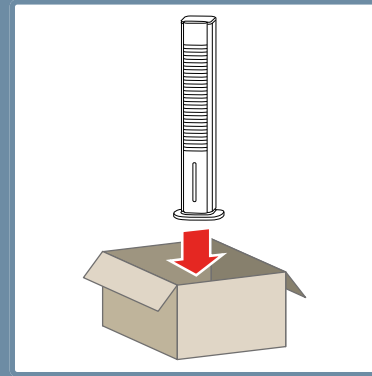

Store the appliance in a dry place away from direct sunlight.

Cleaning

1. Wipe the appliance

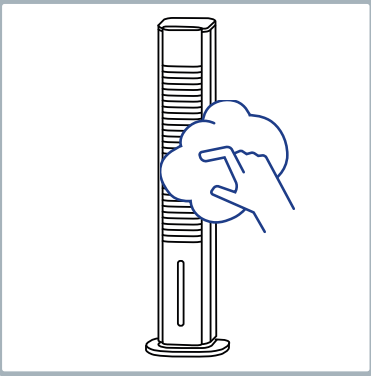

Wipe the appliance with a damp cloth.

2. Remove the filter

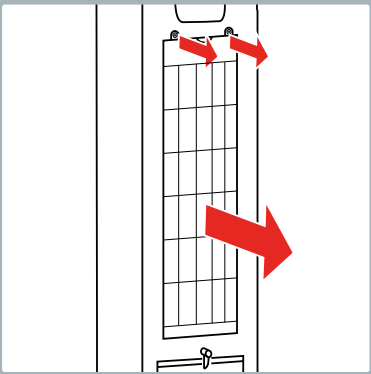

Loosen the screws, remove the filter grille and remove the evaporation mat.

3. Remove the evaporation mat

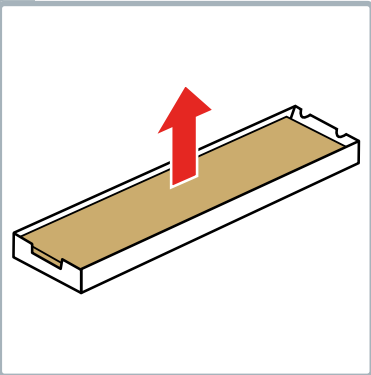

Remove the evaporation mat from the filter grid.

4. Rinse the evaporation mat

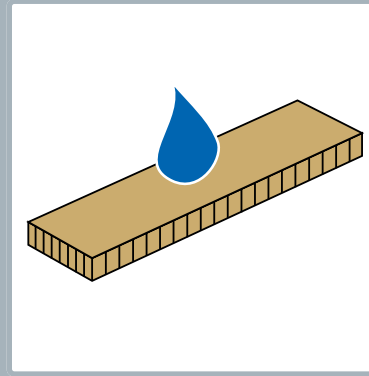

Rinse the evaporation mat with lukewarm water. Then allow to dry completely.

! Replace the evaporation mat if it is dirty.

5. Insert the evaporation mat

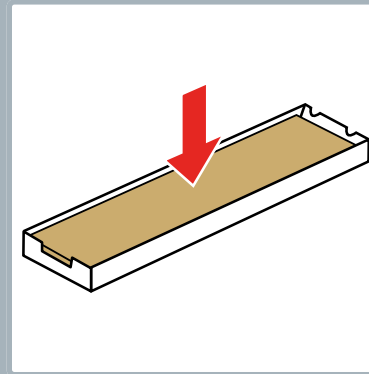

Insert the evaporation mat into the filter grid.

6. Insert the filter

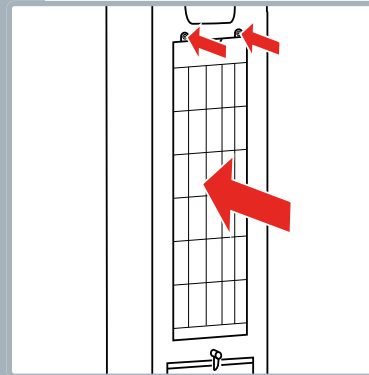

Insert the filter grid and screw it tight.

7. Remove the water tank

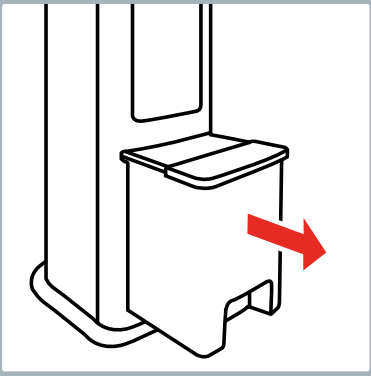

Pull out the water tank.

8. Remove the pump

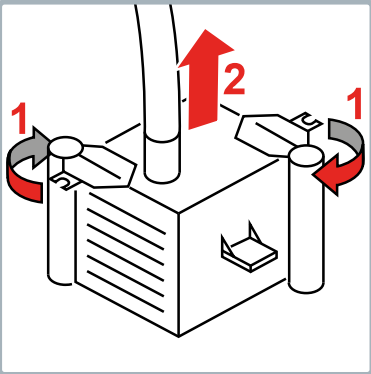

Turn the fasteners outwards and carefully remove the pump from its holder.

9. Rinse out the water tank

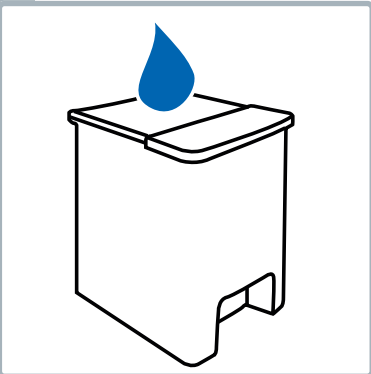

Wash and rinse the water tank thoroughly.

10. Insert the pump

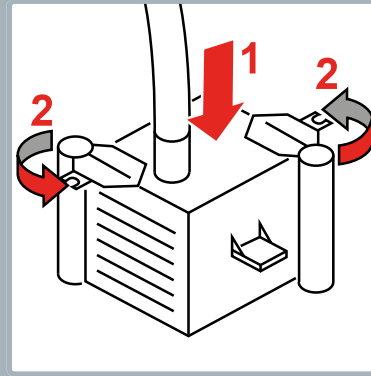

Insert the pump into the holder and turn the fasteners inwards.

11. Insert the water tank

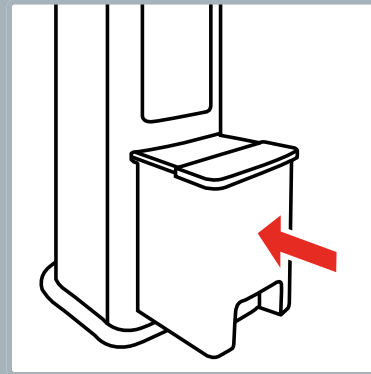

Insert the water tank into the appliance.

Problems and causes

Problem/Cause	Solution
Device not working	Is the device plugged in/switched on?
Air flow is not cool	No/too little water in the tank? Pump not connected to the hose? Cooling elements no longer cold?
Remote control not working	Are the batteries charged and inserted correctly? Is the distance to the device too great?

User information



We provide a 5-year warranty for this device from the date of purchase. The warranty covers the replacement or repair of a device with material or manufacturing defects. Replacement with a new device or return with a refund of the purchase price is not possible. The warranty does not cover normal wear and tear, commercial use, changes to the original condition, cleaning work, consequences of improper handling or damage caused by the purchaser or third parties, damage attributable to external circumstances or damage caused by batteries. The warranty requires that the defective device be sent in at the purchaser's expense with the warranty card dated and signed by the point of sale or with the purchase receipt.

Disposal/environmental protection

Never dispose of this device in household waste, but in accordance with local regulations. Only use official collection points in your municipality. If devices are disposed of in an uncontrolled manner, harmful substances can escape and poison the food chain, flora and fauna. Your point of sale is obliged to take back old devices. Immediately render disused devices unusable. Unplug the power plug and cut the power cord.

Distribution

CH Trisa Electronics AG
Kantonsstrasse 121
CH-6234 Triengen
info@trisaelectronics.ch
+41 41 933 00 30

DE Ernst Lorch KG
Bildstockstraße 9
D-72458 Albstadt
HG@lorch-gruppe.com
+49 (7431) 124 200

AT SCD Handels GmbH
Unterhaus 33
A-2851 Krumbach
service@trisaelectronics.at
+43 (2647) 4304070

BG Trisa Ltd.
43A, Gorski Patnik Street
BG- 1421 Sofia

5 YEARS
GUARANTEE

