

**5** YEARS  
GUARANTEE

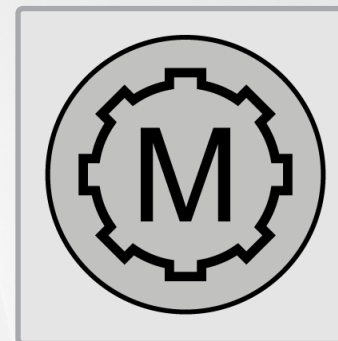

Cooling, drying, automatic switch-on and other practical functions.

**Use:** Page 10

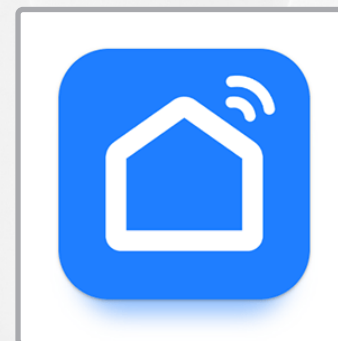

Appliance can connect to Wi-Fi for control via SmartLife app.

**App connection:** Page 9

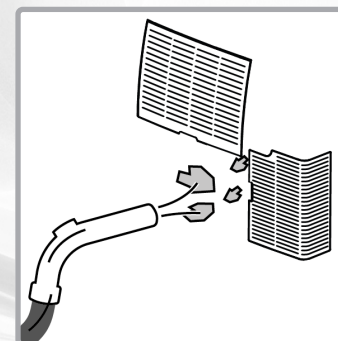

Clean appliance and filter regularly for best performance.

**Cleaning:** Page 14

# Welcome



**Please read all the information contained in these instructions for use. Keep the instructions for use in a safe place and pass them on to subsequent users. The device may only be used for its intended purpose in accordance with these instructions. Observe the safety instructions. The device is best operated with an RCD circuit breaker (max. 30mA).**



Complies with the European directives on safety and EMC.

We reserve the right to make changes to the design, equipment and specifications. Errors and omissions excepted.



**Spare parts and accessories shop**

<https://www.trisaelectronics.ch/en/zubehoer/>

# Table of Contents

<b>Safety instructions</b>	<b>4</b>	<b>After use</b>	<b>12</b>
<b>Specifications</b>	<b>5</b>	<b>Replacing the battery</b>	<b>13</b>
<b>Overview of devices</b>	<b>6</b>	<b>Cleaning</b>	<b>14</b>
<b>Getting started</b>	<b>7</b>	<b>Drain condensation</b>	<b>15</b>
<b>Condensation drain with hose</b>	<b>8</b>	<b>Problems and causes</b>	<b>16</b>
<b>App connection</b>	<b>9</b>	<b>User information</b>	<b>18</b>
<b>Use</b>	<b>10</b>		

# Safety instructions

- Anyone who assists with servicing work must be under the constant supervision of a trained specialist
- Observe the minimum size of rooms in which the appliance may be operated.
- If a refrigerant leak is suspected, switch off the appliance immediately and ventilate the room. The refrigerant is odourless. Do not put the appliance back into operation until it has been inspected in accordance with an officially recognised procedure for the safe handling of refrigerants by a person with industry accreditation.



**WARNING:** Only operate and store the appliance in rooms where there are no permanent sources of ignition. Sources of ignition include in particular open flames (e.g. gas hobs, candles, fireplaces, switched-on electrical appliances, spark-generating devices).



Do not cover the appliance while in operation with blankets, cloths or objects – fire hazard!



Never use near water (baths, sinks, etc.). Do not expose to rain or moisture. Only use the device with dry hands! If the device falls into water, have it checked by a specialist before using it again.

- Do not spray insect spray on the appliance as this will damage it.
- Never direct the appliance's airflow directly at children / animals.
- Read all safety instructions, observe the instructions for use, keep them in a safe place and pass them on to subsequent users.
- The appliance is intended for domestic use, not for commercial use. Do not operate the appliance outdoors.
- Not for household waste. The device must be disposed of in accordance with local regulations.

- If the device is misused, operated incorrectly or repaired improperly, no liability can be accepted for any damage that occurs. In this case, the warranty claim is void.
- Never immerse the device in water or other liquids. No liquid must be allowed to enter the interior of the device (risk of short circuit).
- Check the device, power cord and extension cord for damage before each use. Never use damaged devices (including power cords) – have them repaired or replaced by the manufacturer, its service centre or qualified specialists. Never open the device yourself – risk of injury!
- Do not insert fingers or objects into device openings. Do not cover device openings.
- Avoid operating the device in the vicinity of flammable vapours.
- Children must not play with the device. Keep the device and power cord away from children under 8 years of age. Never leave the device unattended during operation. Packaging material (e.g. plastic bags) must be kept out of the reach of children.
- Mains connection: The voltage must correspond to the specifications on the device's type plate.
- Never carry or pull the device by the power cord. Do not kink, pinch or pull the power cord over sharp edges. Risk of short circuit due to cable breakage!
- Never place the device/connection cable on hot surfaces (hotplates) or near open flames. Do not expose the device to intense heat (heating sources, radiators, sunlight). Only extinguish burning devices with a fire blanket.
- Never pull the plug on the power cord or with wet hands. Unplug the device in the event of malfunctions during use, before refilling, before cleaning, before moving or after use. The plug must remain accessible at all times.

- Switch off unused/unattended devices and pull out the mains plug. Do not wrap the mains cable around the device.
- Only operate the device on a flat, stable, dry surface. Never attach it to a wall or ceiling.
- Children aged 8 years and above and persons with reduced physical, sensory or mental capabilities, or lack of experience and knowledge, may only use the device if they are supervised by a person responsible for their safety or if they have been shown how to use the device safely and understand the dangers involved. Cleaning and maintenance work must not be carried out by children without supervision.
- For safety reasons, do not use accessories that are not recommended/sold by the manufacturer.



First read the operating instructions before putting the appliance into operation



This appliance must be serviced/cleaned regularly. See chapter **Cleaning**.

Repairs and servicing work may only be carried out by certified specialists with industry accreditation.

# Specifications

## Item 9378.70

<b>12,000 BTU/h</b>	Cooling capacity	<b>10,000 BTU/h</b>	Heating capacity	<b>AC 220–240 V / 50 Hz</b>	Voltage / Frequency
<b>6.5 m<sup>3</sup>/min</b>	Maximum air flow	<b>45 W</b>	Fan power consumption	<b>R290</b>	Refrigerant
<b>5–35 °C</b>	Operating temperature range	<b>390 m<sup>3</sup>/h</b>	Air circulation	<b>≤ 65 dB(A)</b>	Noise level
<b>30–50 m<sup>2</sup></b>	Recommended room size	<b>42.3 × 34.8 × 69.4 cm</b>	Dimensions (D × W × H)	<b>29 kg</b>	Weight

## Power consumption

<b>1350 W</b>	If on	<b>2 W</b>	Standby	<b>*12 h</b>	Off/standby mode active after
---------------	-------	------------	---------	--------------	-------------------------------

*\* in sleep mode*

# Overview of devices

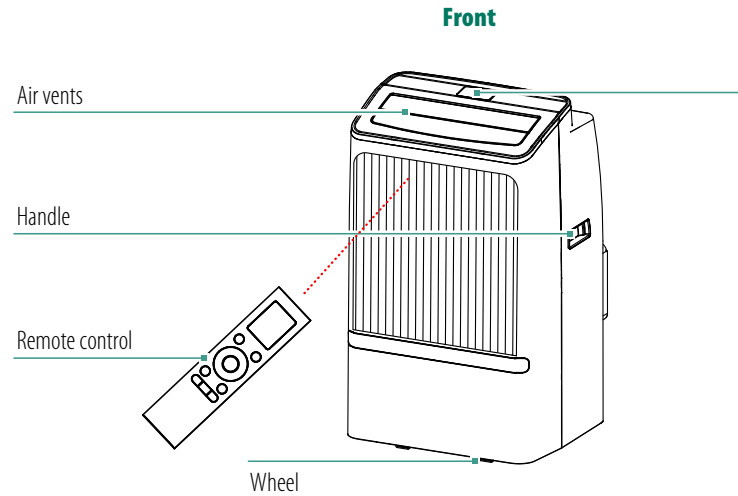

## Control panel

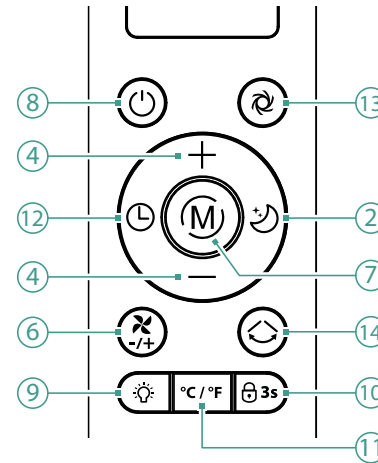
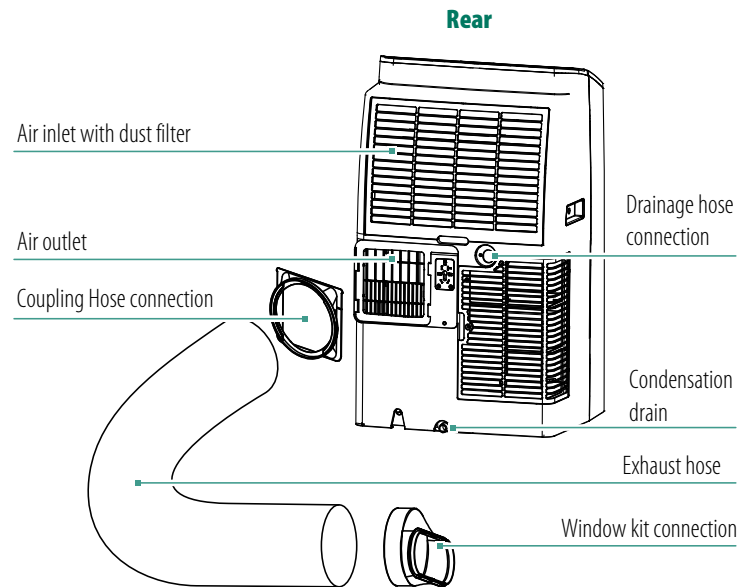
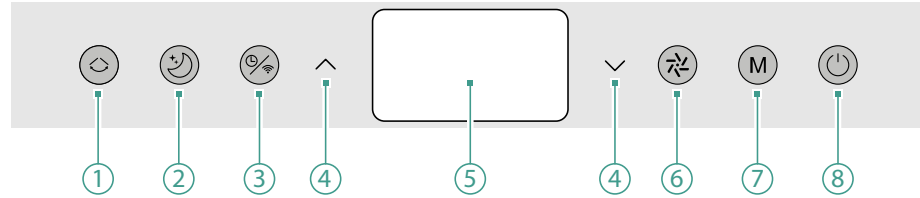

- |  |   |
|--|---|
| ① Oscillation on/off<br>Child lock: press and hold for 5 seconds | ⑧ On/off switch                                 |
| ② Sleep mode on/off  | ⑨ Turn display on/off                           |
| ③ Timer / WiFi<br>Reset Wi-Fi: press and hold for 5 seconds      | ⑩ Child lock                                    |
| ④ Change settings  | ⑪ Change<br>Press the button repeatedly<br>◀▶◂◃ |
| ⑤ Display  | ⑫ Timer   |
| ⑥ Fan speed<br>There are 3 fan speeds to choose from             | ⑬ Max. cooling power on/off                     |
| ⑦ Modes<br>Drying / Ventilation / Cooling / Heating              | ⑭ Oscillation on/off                            |

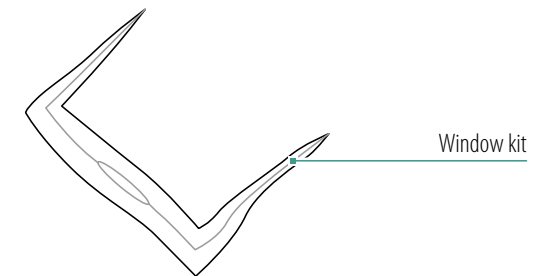
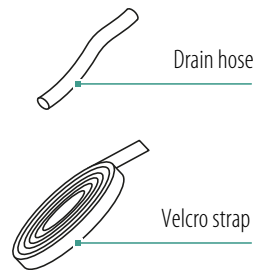

**Spare parts and accessories shop**  
<https://www.trisaelectronics.ch/en/zubehoer/>

# Getting started

## 1. Select installation location

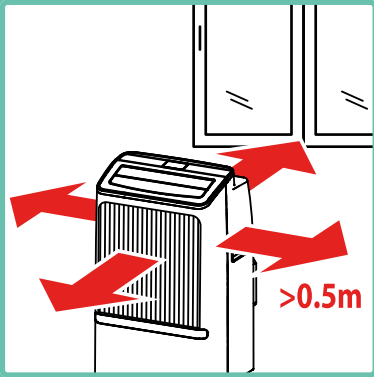

Position the air conditioner near a window.

- ! Maintain the minimum clearance from surrounding objects!
- ! The room in which the appliance is installed, operated and stored must not be smaller than 9 m<sup>2</sup>!
- ! Leave in an upright position for 24 hours to allow the refrigerant to settle in the system.
- ! Remove the adhesive strips from the appliance.

## 2. Connect exhaust air hose

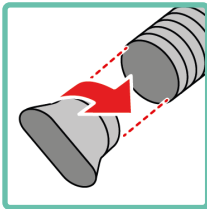
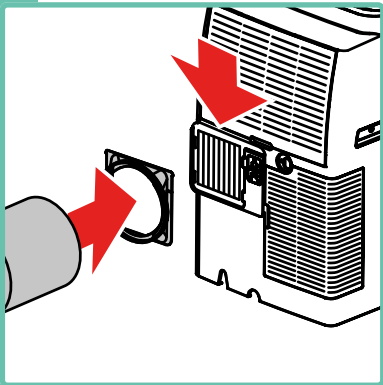

Attach the coupling to the exhaust air hose, then fit it to the air conditioner. Attach the oval coupling to the other end of the exhaust air hose.

## 3. Affixing the Velcro tape

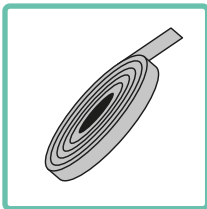
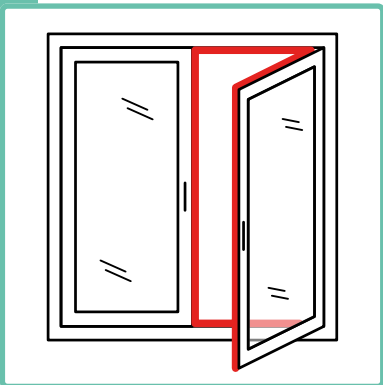

Stick the Velcro tape along the window frame/window sash.

## 4. Seal off window

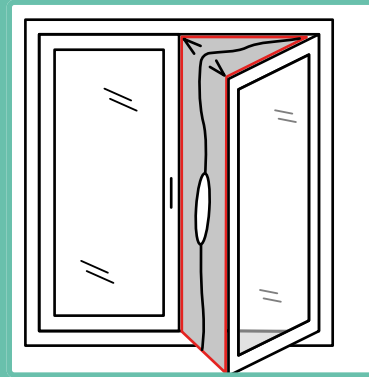

Affix the window kit between the window casement and the window frame.

## 5. Insert exhaust air hose

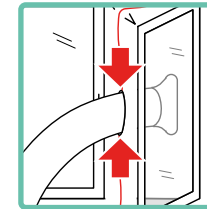
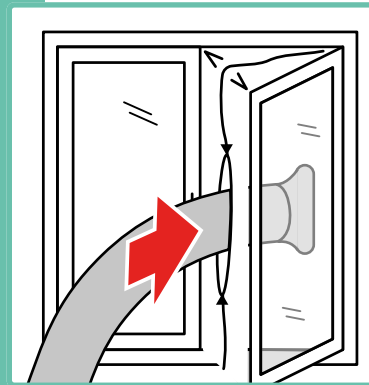

Guide the exhaust air hose through the window kit and secure it with the zip fastener.

## 6. Insert batteries

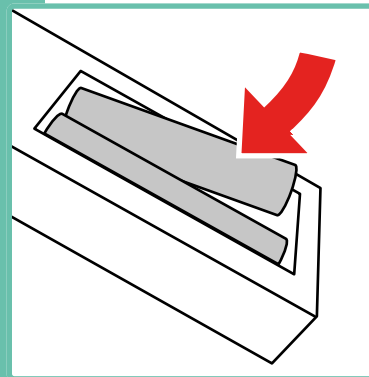

Insert 2x AAA batteries into the remote control.

- ! Pay attention to polarity. Use batteries of the same type and charge!

# Condensation drain with hose

**i** The collected condensation is drained away via the hose to allow the appliance to operate continuously.

## 1. Remove cover

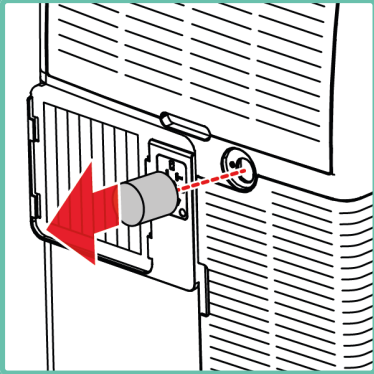

Remove the cover on the drainage hose connection.

**i** The connection is located on the back of the appliance.

## 2. Connect hose

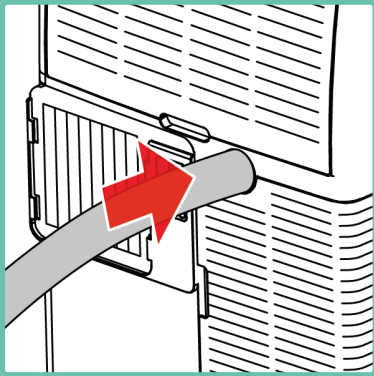

Connect the drainage hose.

! Ensure a good, watertight connection!

## 3. Install hose

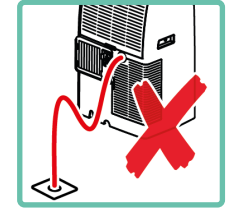
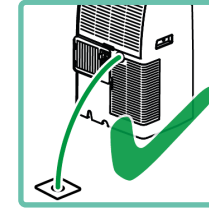
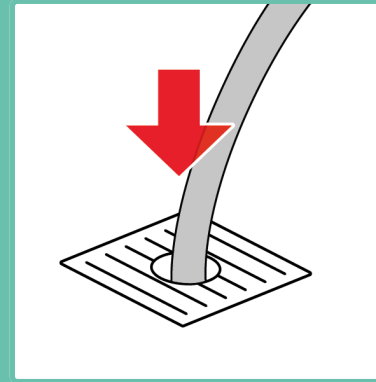

Run the hose into a drain or large container.

- ! It must point downwards! The end of the hose must not be immersed in water.
- ! Ensure that there are no kinks in the hose!

# App connection

## 1. Set up your mobile device



Connect the mobile device to Wi-Fi.

- i** Connect the mobile device to the network to which the device is to be connected.
- !** The device can only be connected to a 2.4 GHz network.

## 2. Set up app



Download the "SmartLife" app and register or log in.

- i** The app requires location and Bluetooth access. Both must be activated and enabled.

## 3. Enable Wi-Fi



Press and hold **the timer button** for 5 seconds to start the network configuration.

- i** To reset the network configuration, press and hold for 5 seconds again

## 4. Add appliance

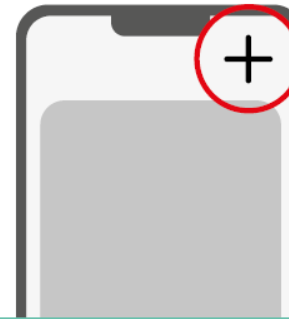

Select add new appliance in the app.

- i** The appliance might appear immediately on the app home page and can be added from there. Otherwise, you can add a new appliance at the top right.

## 5. Select appliance

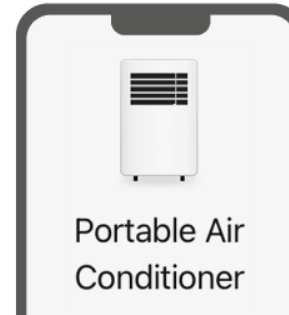

Select the corresponding appliance type in the list.

- !** The appliance icon displayed in the app may differ from the actual appearance of your appliance.

## 6. Complete setup



Follow the instructions in the app and enter your network login details when prompted.

- i** If the connection is successful, the WiFi symbol on the appliance will light up.

# Use

## 1. Plug in

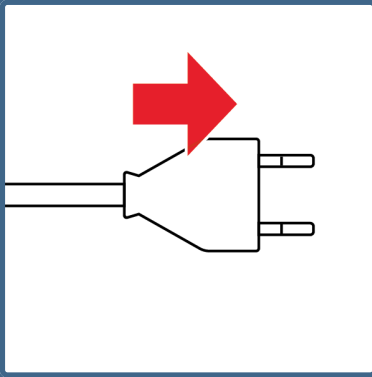

Plug in the mains plug.

! The mains voltage must correspond to the specifications on the type plate.

## 2. Switch on

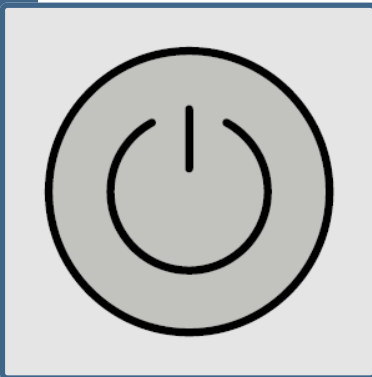

Tap the **Power** button to switch the appliance on.

## 3. Configure

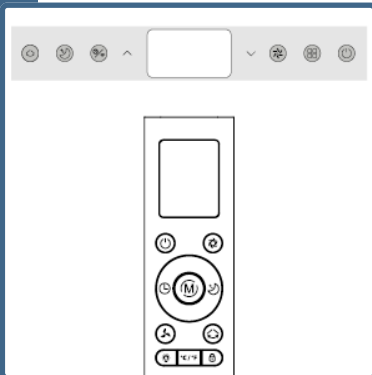

Use the control panel or remote control to make your desired settings.

## 4. Mode

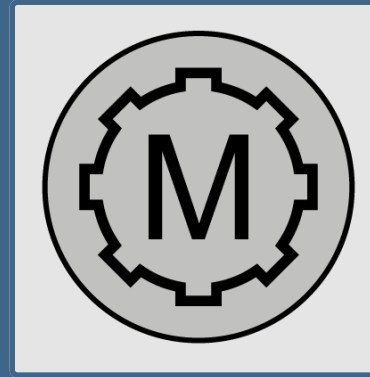

Change the mode by tapping the **Mode** button.

Modes:

**Ventilate, cool, dehumidify, heating**

i In dehumidification mode, the fan speed automatically changes to Slow and you cannot set the temperature.

## 5. Speed

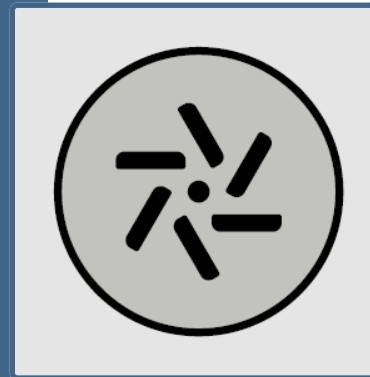

In ventilation/cooling mode, the fan speed can be changed by tapping the "Speed" button.

Speeds:

**Slow**

**Medium**

**Fast**

## 6. Target temperature

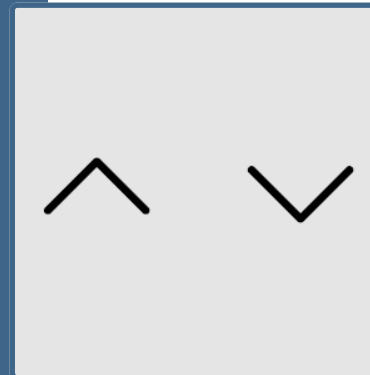

In cooling mode and heating mode, the target temperature can be adjusted by pressing the "**Down/Up**"- button.

Temperature range:

16°C – 32°C

! In heating mode, the target temperature must be set higher than the room temperature.

## 7. Timer



When the appliance is switched on: Tap the **Timer** button, then tap the **Up/Down** buttons to set the time remaining until the appliance switches off.

When the appliance is switched off: Tap the **Timer** button, then tap the **Up/Down** buttons to set the time remaining until the appliance switches on.

**i** Timer can be set from **1-24h**.

**i** Set the timer to **00** or tap the **Power** button to deactivate the timer.

## 8. Sleep mode



In cooling mode, sleep mode can be activated by tapping the **Sleep** button.

**i** In sleep mode, the target temperature is increased by 1°C every hour. After two hours, the target temperature remains unchanged.

## 9. Oscillation

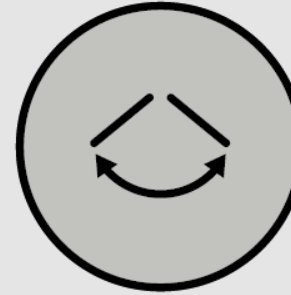

Turn oscillation on/off

**i** Press and hold for 5 seconds to activate/deactivate the child lock.

# After use

## 1. Switch appliance off

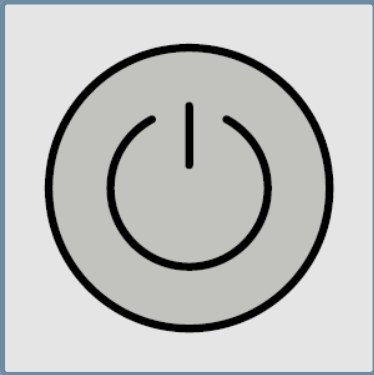

Tap the **Power** button to switch off the appliance.

## 2. Unplug appliance

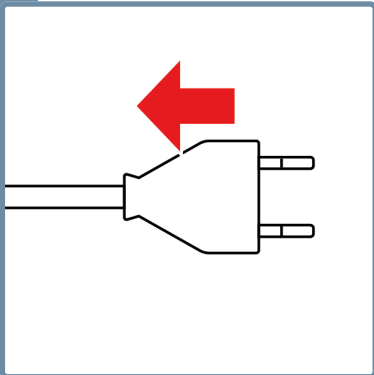

Unplug the mains plug.

## 3. Remove exhaust air hose

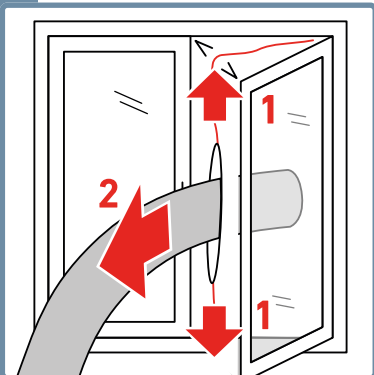

Open the zip fasteners and remove the exhaust air hose.

## 4. Drain condensation

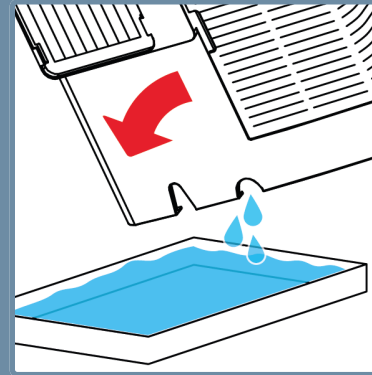

Drain any remaining condensation from the appliance.  
See chapter **Drain condensation**.

## 5. Clean appliance

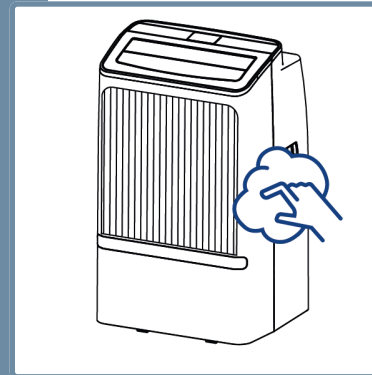

Clean the appliance thoroughly. See chapter **Cleaning**.

## 6. Store appliance

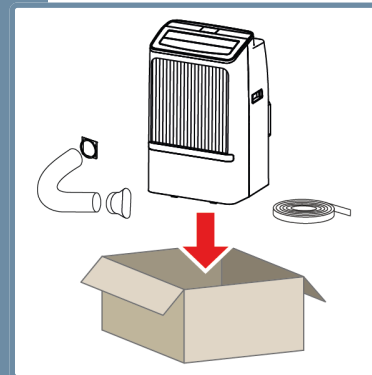

Store the appliance, exhaust air hose and window kit in a well-ventilated, dry and non-corrosive indoor environment.  
**!** Always store the appliance in an upright position.

# Replacing the battery

## 1. Open battery compartment

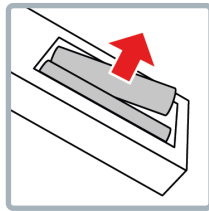
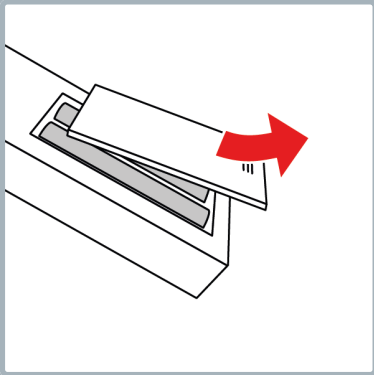

Open the battery compartment and remove the old batteries.

## 2. Insert batteries

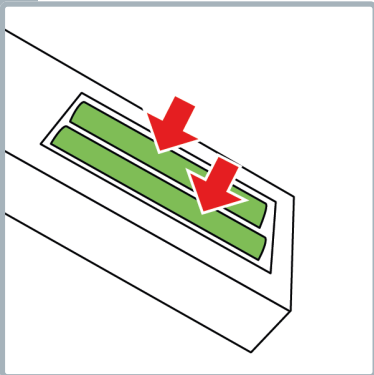

Insert 2x AAA batteries into the remote control.  
! Pay attention to polarity. Use batteries of the same type and charge!

## 3. Close battery compartment

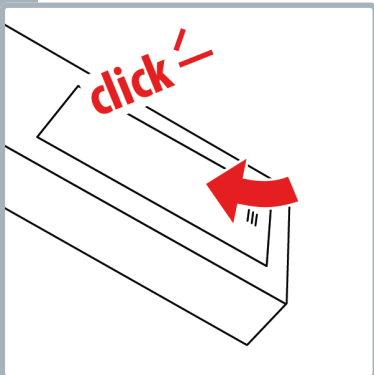

Put the cover on and click it in place over the battery compartment.

# Cleaning

## 1. Switch appliance off

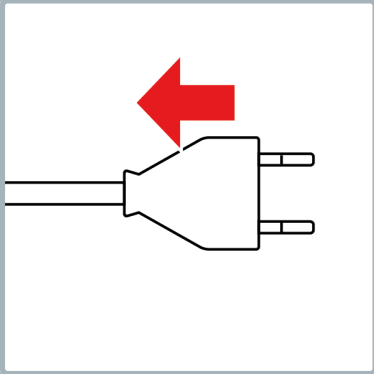

Switch off the appliance and wait for it to come to a standstill, then unplug it.

! If the appliance needs to be repositioned, be careful not to spill any water as you move it.

## 2. Remove dust filter

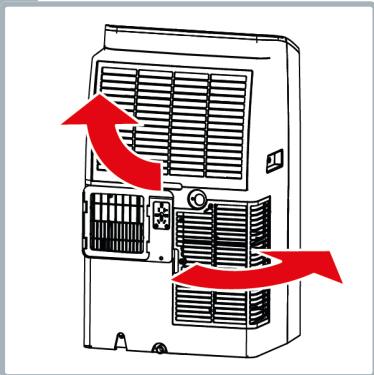

Remove the dust filters from their holders.

! Do not touch the inside of the unit. Risk of injury from sharp-edged fins.

## 3. Vacuum dust filter

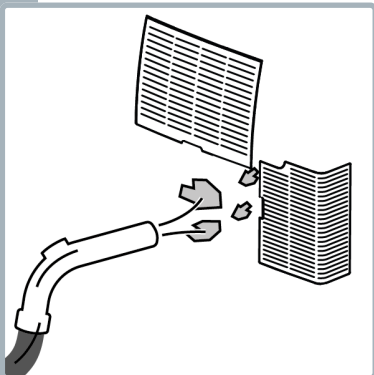

Vacuum the dust filter using a vacuum cleaner.

## 4. Rinse dust filter

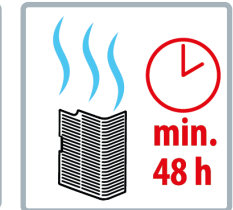
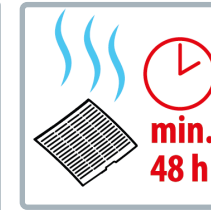
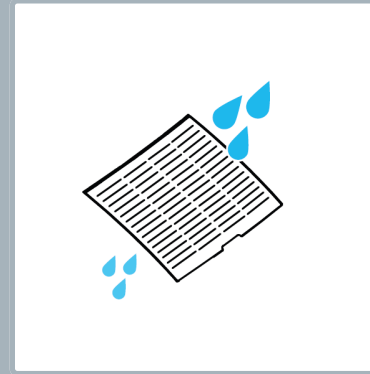

Turn both dust filters over and rinse them under running water.

! Do not use soap or brushes!

## 5. Insert dust filter

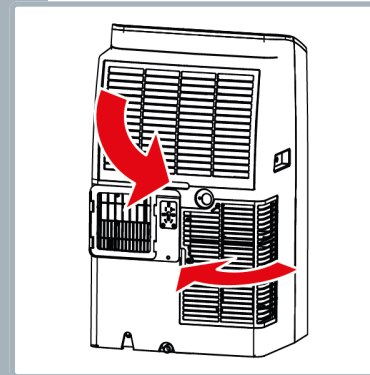

Fit both dust filters to the appliance.

i The dust filters are correctly fitted when they click into place audibly and are properly seated.

! Never switch on or operate the appliance without the dust filters fitted!

## 6. Wipe off appliance

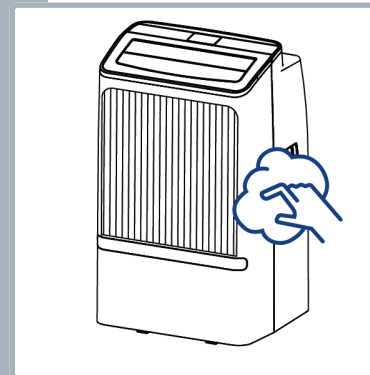

Wipe the device surface with a damp cloth and leave it to dry.

! Do not use abrasive cleaning products or sponges.

# Drain condensation

## 1. Switch appliance off

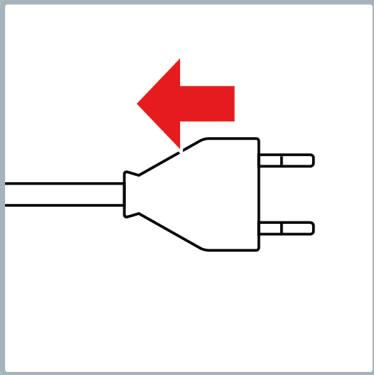

Switch off the appliance and wait for it to come to a standstill, then unplug it.

- ! If the appliance needs to be repositioned, be careful not to spill any water as you move it.

## 2. Put tray in place

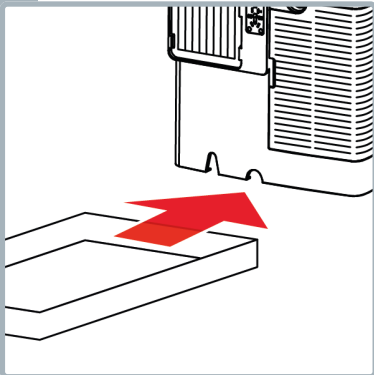

Place a tray under the condensation drain.

- ! Make sure that the tray can hold a sufficient volume of water.

## 3. Open drain

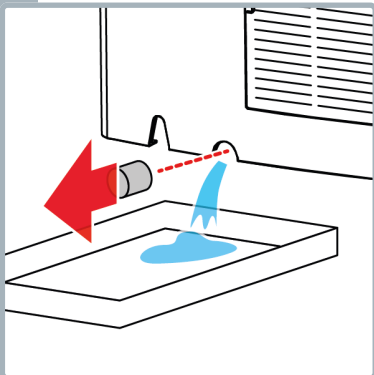

Remove the cover on the condensation drain.

- ! Caution: The water will run out of the drain immediately.
- Make sure that the tray is correctly positioned under the drain.

## 4. Tilt appliance slightly

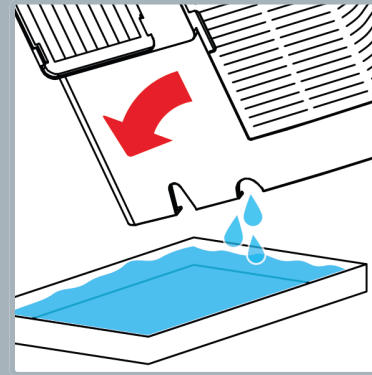

Tilt the appliance carefully and just enough to allow all the water to drain out completely.

- i Alternatively, connect the drainage hose to facilitate draining.

## 5. Close drain

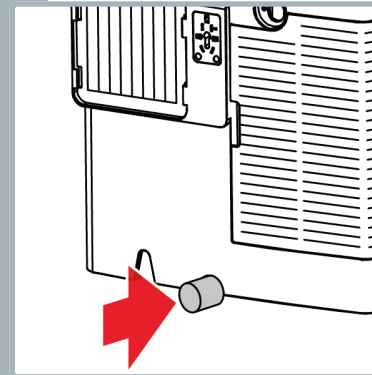

Put the cover back on and ensure that it is fitted tightly.

- ! Close the drain in good time if the tray is not large enough to hold all the water.

# Problems and causes



Problem/cause	Solution
Appliance does not run	Is the appliance plugged in? Have you drained out the condensation? (see chapter <b>Drain condensation</b> ). Is the ambient temperature within the operating temperature range?
The appliance has reduced output	Is the dust filter clean? (see chapter <b>Cleaning</b> .) Is the exhaust air hose blocked? Are windows or doors open? Have you set the correct mode and target temperature?
Water leaks from appliance	Did you drain the condensation before transporting/storing/repositioning? Did you connect the drainage hose properly and make sure it has no kinks?
Increased and abnormal noise level	Is the appliance on a stable and level surface? Are there any loose parts on the appliance?
Cooling output is reducing	Possible refrigerant leak. Contact Trisa Electronics customer service.

## Display indicators

## Solution

---

E1, E2, E3

There is a problem with the electronics. Switch off the appliance, wait for it to come to a standstill and then unplug it. Put the appliance back into operation after 3 minutes. Contact our customer service if the problem persists.

---

FT

The condensation tank is full. Drain the condensation (see chapter **Drain condensation**).

---

# User information



We provide a 5-year warranty for this device from the date of purchase. The warranty covers the replacement or repair of a device with material or manufacturing defects. Replacement with a new device or return with a refund of the purchase price is not possible. The warranty does not cover normal wear and tear, commercial use, changes to the original condition, cleaning work, consequences of improper handling or damage caused by the purchaser or third parties, damage attributable to external circumstances or damage caused by batteries. The warranty requires that the defective device be sent in at the purchaser's expense with the warranty card dated and signed by the point of sale or with the purchase receipt.



## Disposal/environmental protection

Never dispose of this device in household waste, but in accordance with local regulations. Only use official collection points in your municipality. If devices are disposed of in an uncontrolled manner, harmful substances can escape and poison the food chain, flora and fauna. Your point of sale is obliged to take back old devices. Immediately render disused devices unusable. Unplug the power plug and cut the power cord.

## Distribution

**CH** Trisa Electronics AG  
Kantonsstrasse 121  
CH-6234 Triengen  
info@trisaelectronics.ch  
+41 41 933 00 30

**DE** Ernst Lorch KG  
Bildstockstraße 9  
D-72458 Albstadt  
HG@lorch-gruppe.com  
+49 (7431) 124 200

**AT** SCD Handels GmbH  
Unterhaus 33  
A-2851 Krumbach  
service@trisaelectronics.at  
+43 (2647) 4304070

**BG** Trisa Ltd.  
43A, Gorski Patnik Street  
BG- 1421 Sofia

**5** YEARS  
GUARANTEE

